

PADPA

AntumbraDisplay American

Contemporary button panel with LCD display

The Philips AntumbraDisplay user interface provides a central LCD display to present multiple pages of functions and system information. It incorporates the latest in field effect technology.

The contemporary design features a number of button configurations, with each button capable of local or site-wide control functions. The PADPA range is suitable for, but not limited to, North American, South American, Australian and New Zealand markets.

PADPA

Contemporary button panel with LCD display

- **Field effect technology*** – The user interface detects an approaching user and ‘wakes up’, initiating a wall-wash lighting effect to encourage interaction.
- **Supplied as two components** – The Application Module contains buttons, rim, base and mounting plate, which can be mixed and matched to suit décor. The Communication Module contains all of the logical and network functions and is pre-programmed off-site, allowing commissioning to commence prior to finish options being finalized.
- **Hidden sensory inputs** – An internal light sensor measures ambient light and adjusts the lightwash effect accordingly. A built-in temperature sensor automatically adjusts air conditioning when integrated into the system.
- **Multiple language and icon labeling** – Button labeling language choices include English, Chinese and Arabic. A library of common icons transcends language barriers, which is particularly useful in hospitality applications.
- **Central LCD** – Allows for display of system information including temperature, time, channel level and current scene. Button function can change when navigating between up to 16 pages.
- **Décor-matching options** – Buttons and rims are available in a range of attractive polycarbonate and metallic finishes.
- **64-channel DMX Tx support** – Can be factory-set to DMX instead of DyNet, to communicate directly with DMX fixtures

* The mounting plate must be grounded to avoid field effect false triggering by nearby ungrounded metal objects.

Dimensions

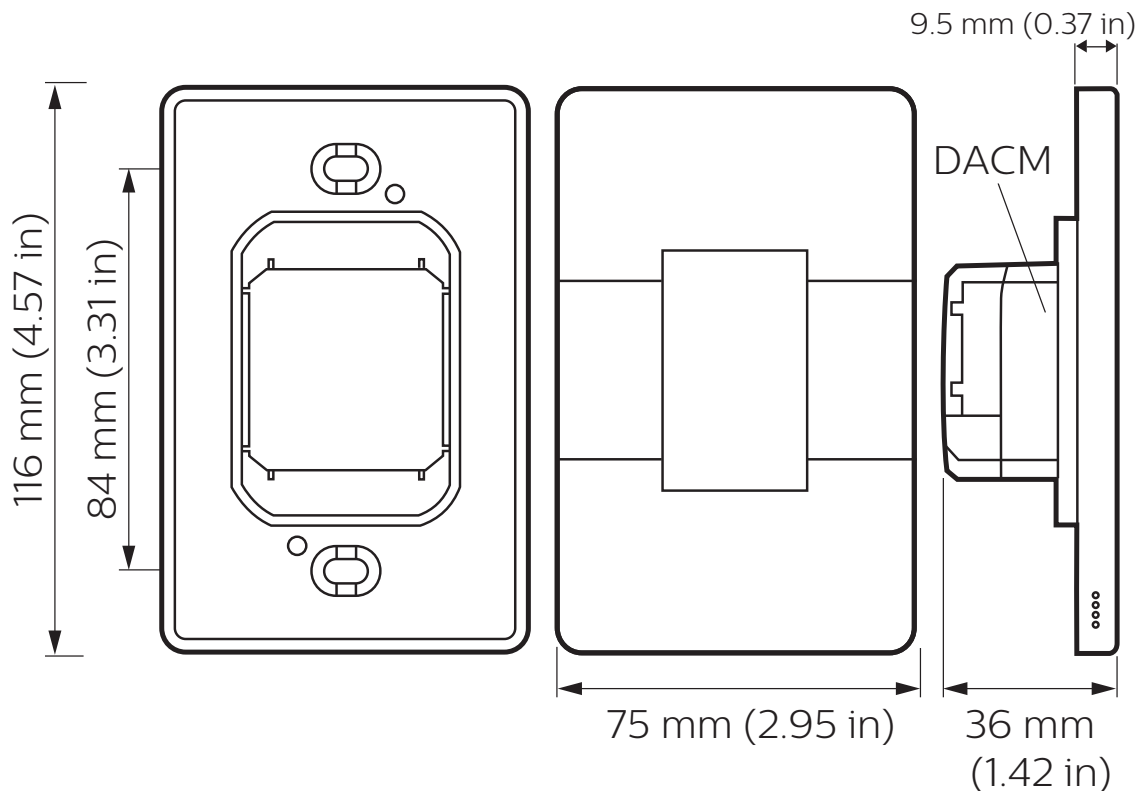

Specifications

Due to continuous improvements and innovations, specifications may change without notice.



PADPA
AntumbraDisplay American

Electrical

Supply Type	DyNet
Supply Voltage	12-24 VDC SELV/Class 2
Supply Current	60 mA @ 12 VDC 35 mA @ 24 VDC

Application Module

User Inputs	6 x software-configurable buttons
Indicators	White indicator LED on each button White wall-wash backlight LCD display
Temperature Sensor Range	5° to 40°C (41° to 104°F)
Temperature Sensor Accuracy	± 0.5°C (± 0.9°F)
Field Effect Detection Range (Typical)	approx. 5 cm (2 in)

Communication Module

Serial Ports	1 x RS-485
Supported Protocols	DyNet DMX Tx
DMX Tx Channels	64
User Inputs	1 x service switch
Indicators	1 x service LED

Physical

Dimensions (H x W x D)	116 x 75 x 36 mm (4.57 x 2.95 x 1.42 in) (fully assembled)
Packed Weight (application module)	0.2 kg (0.44 lb)
Packed Weight (communication module)	0.12 kg (0.25 lb)
Button/Rim Finish	See Page 4
Serial Ports	1 x 5-way pluggable screw terminal +V, D-, D+, GND, SHLD
Serial Port Conductor Size	2.5 mm ² (#12 AWG) (max)

Environment*

Operating Temperature	-5° to 50°C ambient (23° to 122°F)
Storage/Transport Temperature	-25° to 60°C ambient (-13° to 140°F)
Humidity	0 to 90% non-condensing
IEC Pollution Degree	II

Compliance

Certification	CE, RCM, FCC, UL, ICES, EN50491-3, UKCA, RoHS
IP Rating	IP22

* For Indoor Installation Only

Fascia and Rim Finishes

Corona fascia finishes

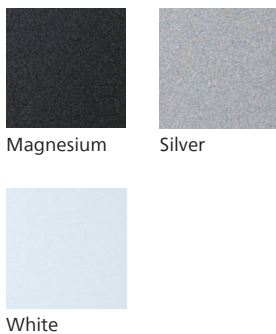

Flare fascia finishes

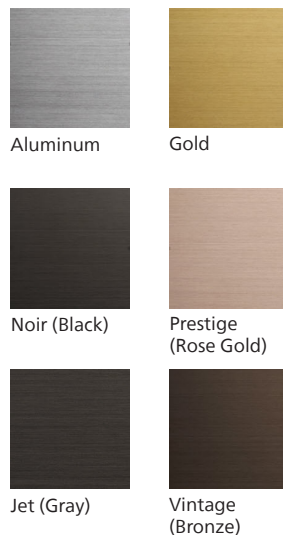

Rim finishes

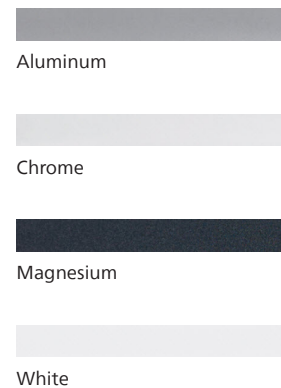

NOTE: Flare colors are created through a batch-controlled anodizing process. Separate batches may vary slightly in color and surface appearance.



AntumbraDisplay Panel Assembly

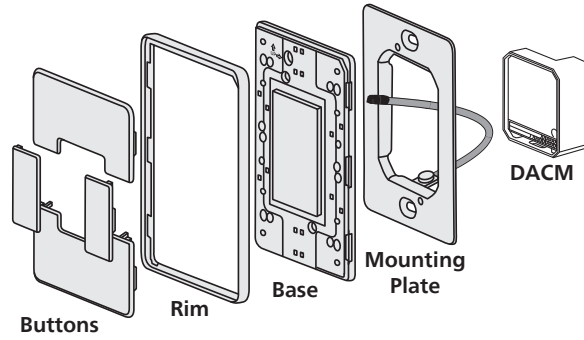

Application Module Ordering Code

The Application Module contains the buttons, rim, base and mounting plate. The buttons and rim are available in the range of finishes shown below. The base contains all the sensors and LED indicators. Sensitive components are enclosed by a rubber envelope to give an IP22 rating, allowing installation in high-condensation environments such as bathrooms. A metal mounting plate attaches the Antumbra panel securely to the wall, ensuring stable, reliable operation.



PADPA-SM-X

Button Finish

Corona (Polycarbonate)

M = Magnesium

S = Silver

W = White

Flare (Metallic)

A = Aluminum

G = Gold

J = Jet

N = Noir

P = Prestige

V = Vintage

Rim Finish

A = Aluminum

C = Chrome

M = Magnesium

W = White

Button Labeling

X = Not Available

Communication Module Ordering Code

The Communication Module is compatible with all interfaces across the Antumbra series, and can be ordered, programmed, installed, wired and tested without the Application Module attached.

This allows the commissioning process to begin before the final finish options have been chosen, or during construction, and protects the Application Module from damage until the site is ready for occupancy.



Product

DACM-DyNet (DyNet communication module)

Philips 12NC

913703072809

Accessories

DINGUS-DUS-DUAL-RJ12 (dual RJ12 connector - pack of 10)

913703064309

DINGUS-UI-DUAL-RJ45 (dual RJ45 connector - pack of 10)

913703334609

© 2024 Signify Holding.

All rights reserved. Specifications are subject to change without notice. No representation or warranty as to the accuracy or completeness of the information included herein is given and any liability for any action in reliance thereon is disclaimed. Philips and the Philips Shield Emblem are registered trademarks of Koninklijke Philips N.V. All other trademarks are owned by Signify Holding or their respective owners.



www.dynalite.com

Revision 19 – 2024-07-10