



DDBC320-DALI

DALI-2 Driver Controller

Full DALI-2 control solution with inbuilt DALI power supply and driver power management

The Philips Dynalite DDBC320-DALI is a three-line controller, ideal for large-scale projects looking for a powerful all-in-one DALI control solution.

This controller operates seamlessly with all other Dynalite controllers, sensors, user interfaces and head-end software, and includes a secured Ethernet port for network communication.

DDBC320-DALI

Power-saving DALI-2 control solution

- **Single-master solution** – Compatible with a range of DALI fittings and devices including DALI fluorescent drivers, DALI electronic low voltage transformers, DALI LED fixtures, DALI emergency lighting fixtures and Philips Dynalite DALI sensors and user interfaces.
- **Compatible with DALI 209 drivers** – Provides control of tunable white and RGBWAF luminaires.
- **Driver standby power elimination** – Internal switched relay automatically isolates each line's power circuit when all drivers are dimmed to 0%.
- **Independent line enumeration** – Commission each DALI line individually without affecting other lines or controller functionality.
- **Auto-enumeration** – Provides automatic enumeration of DALI drivers when powered on and enables self repair of the network system if a DALI driver fails.
- **Silent enumeration** – Constantly checks the DALI bus for changes, automatically enumerating individual driver replacements with no disruption to lighting performance.
- **UL924 Input** – Integrates seamlessly with compatible emergency systems.
- **Fully scalable network solution** – Direct mapping from DALI to the DyNet network protocol eliminates DALI imposed limits, such as maximum group sizes.
- **DALI port protection** – Each DALI port is protected by a self-resettable fuse, preventing damage to devices if exposed to prolonged excessive current from multiple DALI power supplies or accidental shorting to mains. Once fault conditions have been corrected, the device resumes normal operation.
- **Inbuilt Ethernet port** – Directly connecting to a site's LAN, the device can securely report its status and pass network messages via the Dynalite PDDEG-S*.
- **Flexible mounting solution** – A DIN-rail mountable device, designed to be installed into the distribution board, supplying power to the controlled lighting circuit.
- **Dual functionality** – Leverage advantages of a true DALI network solution, whilst still providing access to the full DyNet feature set.
- **Integral DALI bus power supply** – Removes the need for provision of a separate external power supply and reduces distribution board wiring complexity.
- **Driver management tools** – Includes lamp and driver status reporting, driver runtime tracking, and emergency test reporting.
- **Onboard DALI test function** – Use each DALI line's test button to turn all connected drivers on/off, or flash on/off for a 5-minute test window, without the need for software or additional input devices.
- **Onboard line override switch** – Set each DALI line's connected drivers to 100% or 0% brightness without the need for software or additional input devices.

* Each PDDEG-S supports encrypted communication with up to 25 controllers.

Dimensions

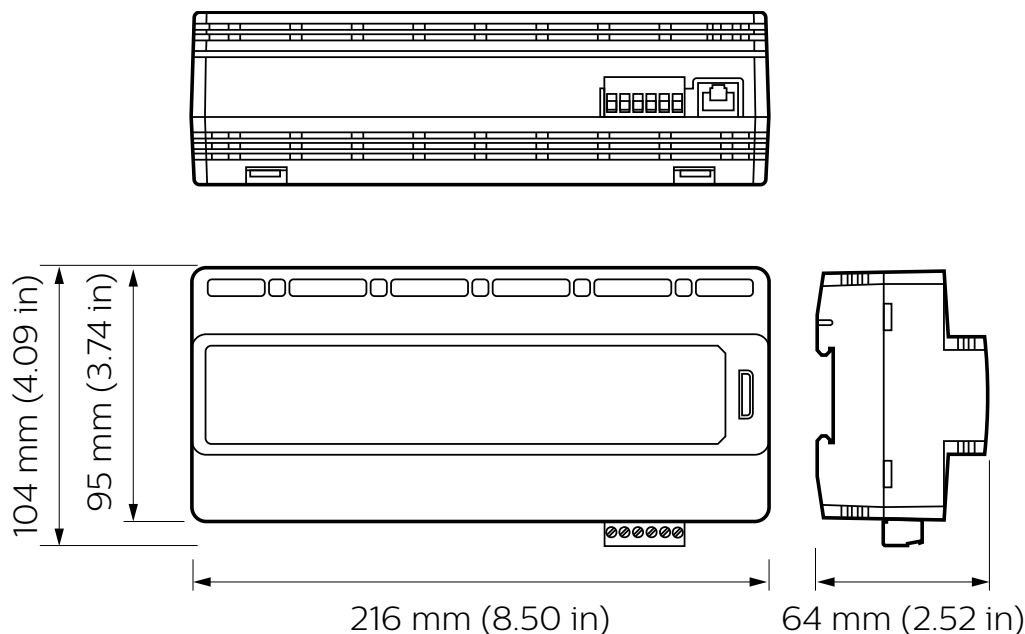

Specifications

Due to continuous improvements and innovations, specifications may change without notice.



DDBC320-DALI
DALI-2 Driver Controller

Electrical

Supply Type	Single-Phase
Supply Voltage	100-277 VAC
Supply Current	0.5 A
DyNet DC Output Voltage	12 VDC
DyNet DC Output Current	300 mA
Switched Outputs	3 x feed-through (See ratings table below)
DALI Protection	Electronic self-resettable fuse
Maximum CH-CH Voltage	500 VAC
IEC Overvoltage Category	III

Control

Serial Ports	1 x RS-485 1 x Ethernet (10/100 baseT)
Supported Protocols	DyNet TCP/IP (TCP, UDP), IPv4, IPv6
Network Security Layer	TLS 1.2
Control Channel Outputs	3 x DALI-2 (DALI-2 certified and DALI registered drivers only) (Supports DALI 207 & DALI 209 Tunable White / RGBWAF)
Dry Contact Inputs	1 (AUX / UL924)
User Input	1 x service switch 3 x DALI line override switch 3 x DALI line test button
Indicators	1 x diagnostic LED 3 x DALI bus status LED 1 x Ethernet activity LED
Diagnostic Functions*	Lamp failure reporting Driver failure reporting Driver runtime tracking Switched output runtime tracking Emergency test reporting Device online/offline status

* Philips Dynalite System Manager required for analyzing diagnostic data.
The availability of some diagnostics is dependent on driver type.

Control Channel Ratings

DALI	DALI Line	Device
Guaranteed Current	220 mA	
Maximum Current	250 mA	
Maximum Drivers	64	192
Insulation	Basic	

Physical

Dimensions (H x W x D)	95 x 216 x 64 mm (3.74 x 8.50 x 2.52 in)
Packed Weight	0.6 kg (1.32 lb)
Construction	Polycarbonate DIN rail enclosure (12 unit)
Serial Ports	1 x RJ45 1 x 6-way pluggable screw terminal
Serial Port Conductor Size	2.5 mm ² (#12 AWG) (max)
Supply Terminals	1 x 3-way screw terminal (Earth, Neutral, Line)
Supply Terminal Conductor Size	0.2-5 mm ² (#24-10 AWG)
DALI Terminals	1 x 6-way screw terminal 3 x (DA-, DA+)
DALI Terminal Conductor Size	0.2-5 mm ² (#24-10 AWG)
Switched Terminals	1 x 8-way screw terminal 3 x (IN, OUT), 2 x (N/A)
Switched Terminal Conductor Size	0.2-5 mm ² (#24-10 AWG)

Environment**

Operating Temperature	-25° to 50°C (-13° to 122°F)
Storage/Transport Temperature	-25° to 70°C ambient (-13° to 158°F)
Relative Humidity	0 to 90% non-condensing
IEC Pollution Degree	II

Compliance

Certification	DALI-2, CE, RCM, UL/cUL, FCC ICES-003, UKCA, RoHS
---------------	--

** For indoor installation only

Output Channel Ratings

Load Type	Maximum Rating DALI Line 1-3:	
	UL/cUL	CE
Electronic Driver	16 A, 277 VAC	20 A, 240 VAC
Pilot Duty	6 A, 120 VAC 3 A, 240 VAC 2.6 A, 277 VAC	
Inrush Current	500 A	

Total Device Load: ≤ 60 A



Electrical

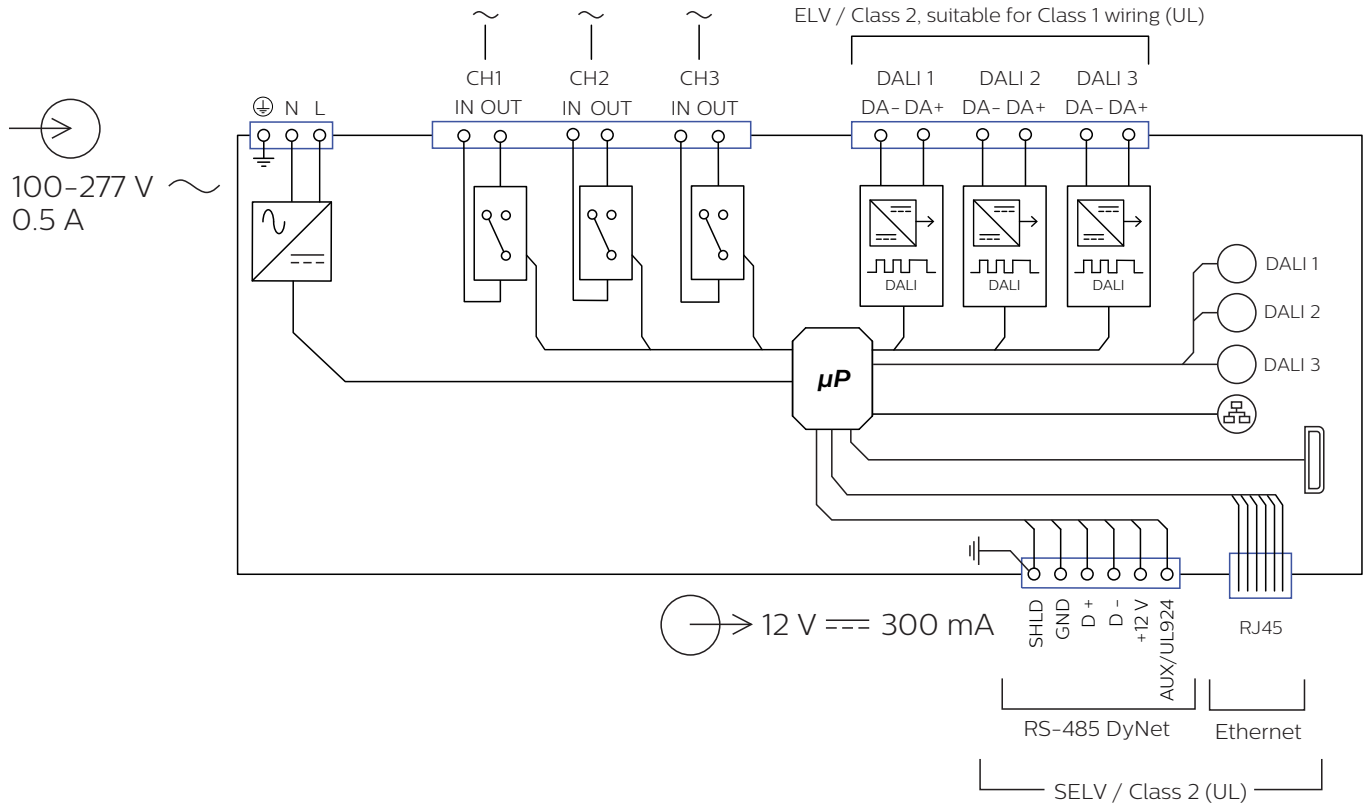

DALI Device Count

The table below shows the maximum number of DALI drivers and Dynalite DALI devices that can be connected to each DALI bus at the same time.

These devices include Dynalite's range of DALI occupancy sensors and the DPMI940-D dry contact interface.

Dynalite DALI Devices	DALI Drivers
10	64
11	59
12	54
13	49
14	44
15	39
16	34

Ordering Code

Product

DDBC320-DALI

Philips 12NC

913703079709

© 2024 Signify Holding.

All rights reserved. Specifications are subject to change without notice. No representation or warranty as to the accuracy or completeness of the information included herein is given and any liability for any action in reliance thereon is disclaimed. Philips and the Philips Shield Emblem are registered trademarks of Koninklijke Philips N.V. All other trademarks are owned by Signify Holding or their respective owners.



www.dynalite.com

Revision 15 – 2024-05-22