

DDRC1220FR-GL

Relay Controller

Robust control of switched loads

The Philips Dynalite DDRC1220FR-GL provides control of multiple types of switched loads. This general-purpose 12 channel controller supports switched loads of up to 20 A per channel, up to a maximum device load of 180 A.

DDRC1220FR-GL

Robust control of switched loads

- **Feed-through power circuit design** – Electrically equivalent to a 12 pole contactor, with the added advantage of each pole being separately controllable via the DyNet network.
- **Flexible mounting solution** – A DIN-rail mountable device, designed to be installed into the distribution board supplying power to the controlled circuit.
- **Inbuilt diagnostic functionality** – Features circuit run time tracking on each channel and Device Online/Offline status indication.
- **Multiple wiring schemes supported** – Controls single phase and neutral or three phase and neutral (star) wiring configurations.
- **Hardware override** – Service override switch accessible from front panel.

Dimensions

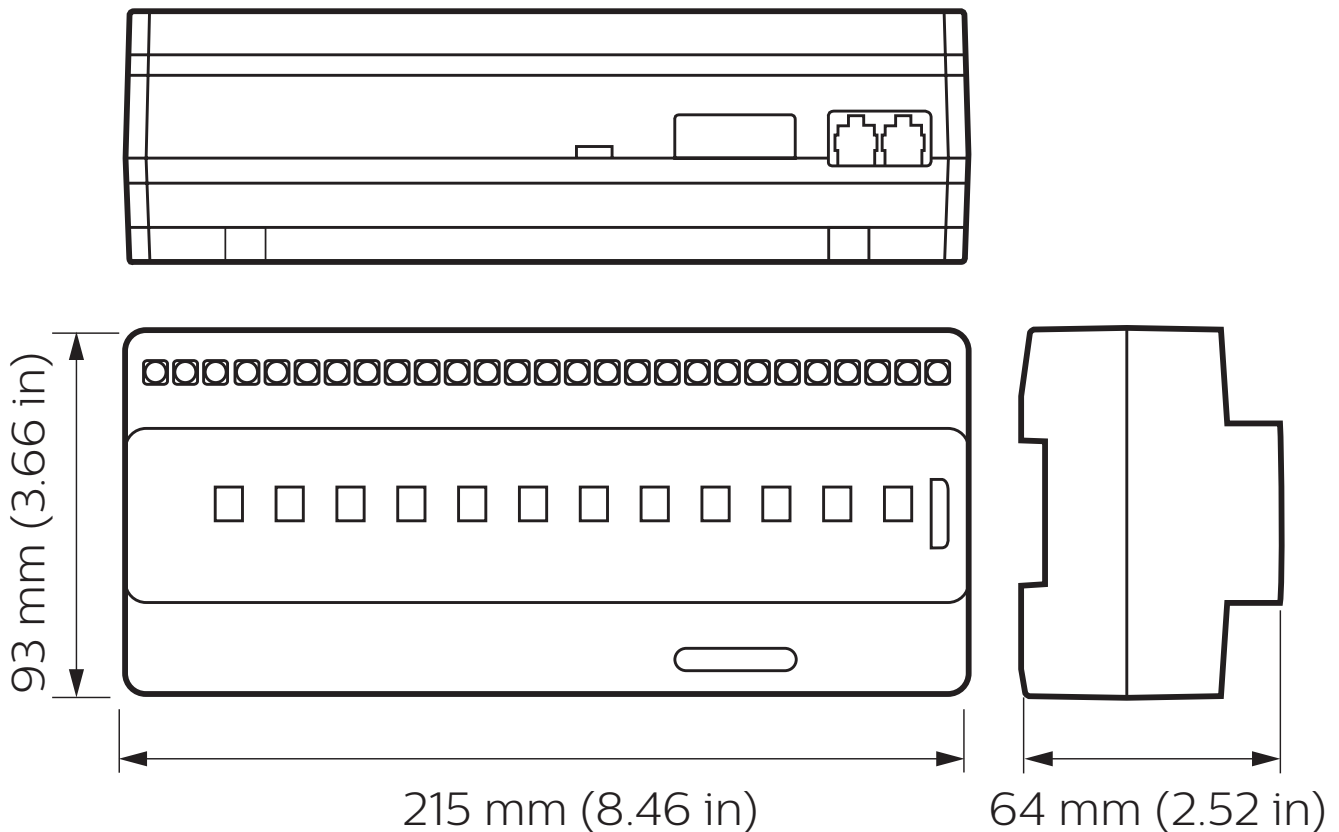

Specifications

Due to continuous improvements and innovations, specifications may change without notice.



DDRC1220FR-GL
Relay Controller

Electrical

Supply Type	Single phase
Supply Voltage	100-240 VAC
Supply Current	0.25 A
Outputs	12 x SPST feed-through relay with manual override
Output Channel Current	20 A (max)
Maximum Device Load	180 A
Output Channel Ratings	(See Load Table on Pg 4)
Maximum CH-CH Voltage	300 VAC (UL) 400 VAC (CE)
Maximum CH-XX-CH Voltage (CH2-12 only) XX = unpopulated channel (2x terminals) for isolation	480 VAC
Supported Wiring Schemes	Single Phase and Neutral Three Phase and Neutral (Star)
DyNet DC Output Voltage	12 VDC
DyNet DC Output Current	200 mA
Overvoltage Category	III

Control

Serial Ports	1 x RS-485
Supported Protocols	DyNet DMX Rx
DMX Rx Channels	12
Dry Contact Inputs	1 (AUX)
Diagnostic Functions	Device online/offline status
User Controls	1 x service switch Manual override switch for each channel
Indicators	1 x diagnostic LED

* Refer to Installation Instructions for correct terminations for phase separation.

Physical

Dimensions (H x W x D)	93 x 215 x 64 mm (3.66 x 8.46 x 2.52 in)
Packed Weight	1.1 kg (2.43 lb)
Construction	Polycarbonate DIN rail enclosure (12 unit)
Serial Ports	2 x RJ12 1 x 6-way pluggable screw terminal SHLD, GND, D+, D-, +12V, AUX
Serial Port Conductor Size	2.5 mm ² (#12 AWG) (max)
Supply Terminals	3 x screw terminal Line, Neutral, Earth
Supply Terminal Conductor Size	5 mm ² (#10 AWG) (max)
Load Terminals	12 x 2-way screw terminal Line IN, Line OUT
Load Terminal Conductor Size	5 mm ² (#10 AWG) (max)

Environment**

Operating Temperature	0° to 50°C ambient (32° to 122°F)
Storage/Transport Temperature	-25° to 70°C ambient (-13° to 158°F)
Relative Humidity	0 to 90% non-condensing
IEC Pollution Degree	II

Compliance

Certification	CE, RCM, UL/cUL, FCC, ICES-003, UKCA, RoHS
---------------	--

** For indoor installation only



Electrical

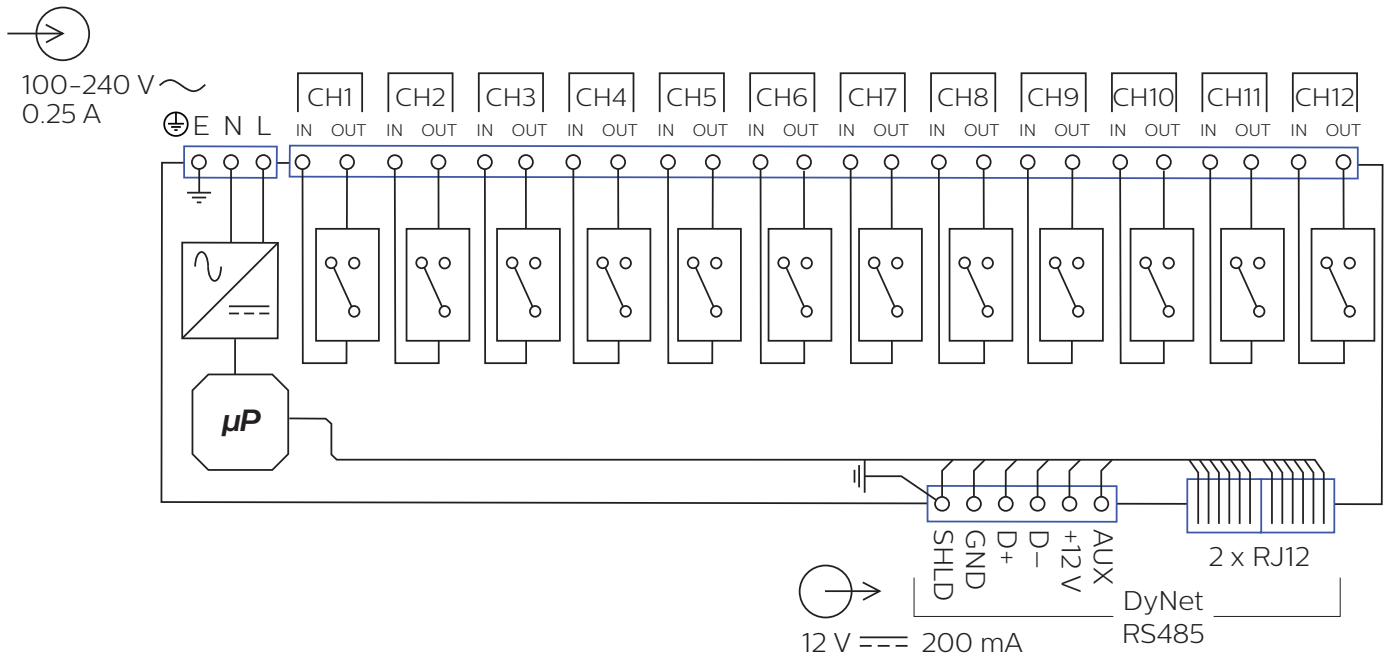

Output Channel Ratings

Load Type	Maximum Rating per Output*	
	UL/cUL	CE
General Use		
Incandescent	16 A, 277 VAC	20 A, 240 VAC
Standard Ballast		
Electronic Ballast	16 A, 277 VAC	
Motor	16 FLA** (1 HP), 120 VAC 14.5 FLA** (2 ½ HP), 240 VAC 14.1 FLA** (3 HP), 277 VAC	
Inrush Current	500 A	

* Note Maximum Device Load and Maximum CH-CH Voltage on Pg 3

** FLA: Full Load Amps

Ordering Code

Product

DDRC1220FR-GL

Philips 12NC

913703243009

© 2024 Signify Holding.

All rights reserved. Specifications are subject to change without notice. No representation or warranty as to the accuracy or completeness of the information included herein is given and any liability for any action in reliance thereon is disclaimed. Philips and the Philips Shield Emblem are registered trademarks of Koninklijke Philips N.V. All other trademarks are owned by Signify Holding or their respective owners.



www.dynalite.com

Revision 12 – 2024-01-17