



DPMI940-D

Dry Contact Interface

Four-way DALI dry contact interface

The Philips Dynalite DPMI940-D is a four-channel input dry contact interface, designed to allow mechanical and electronic switches to interface directly with a Philips Dynalite DALI controller on the DALI bus.

DPMI940-D

Four-way DALI dry contact interface

- **DALI device** – Designed to operate seamlessly with the Philips Dynalite DDBC120-DALI or DDBC320-DALI controller.
- **Powered directly by the DALI network** – Eliminates the need for additional network field wiring.
- **Fully programmable** – Each individual input is fully software programmable over the DALI network, allowing for multiple functions to be performed such as select lighting scene, room join or toggle lighting on/off.
- **Compact size** – Inputs are presented on flyleads, making the device suitable for installation behind multi-gang switch grids.
- **Simple dry contact interface** – Can be used for low level integration to third party systems such as security and air conditioning so that the lighting can be coordinated together with other services found within a project.

Dimensions

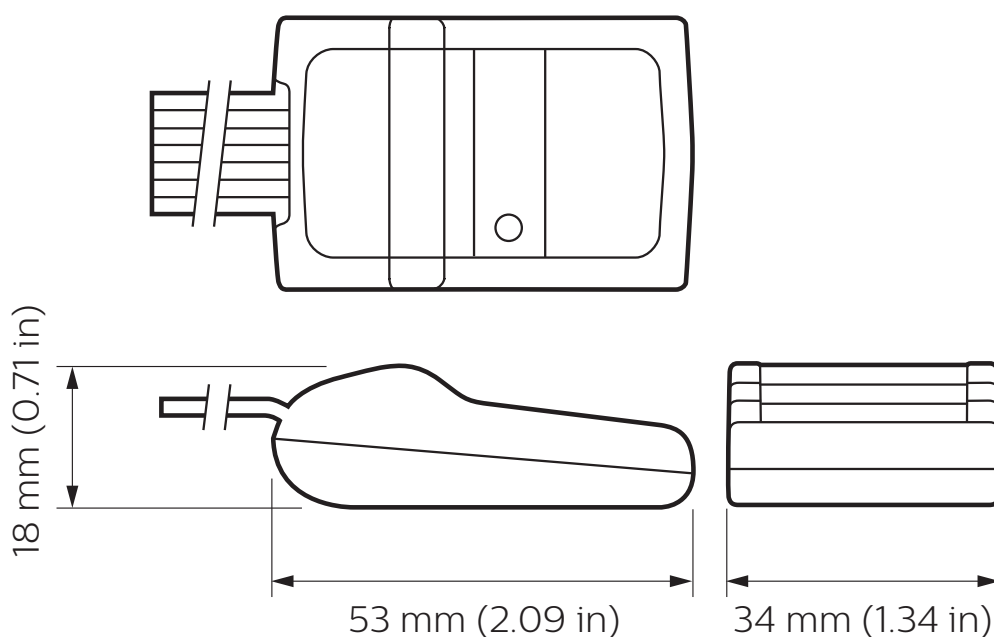

Specifications

Due to continuous improvements and innovations, specifications may change without notice.



DPMI940-D
Dry Contact Interface

Electrical

Supply Type	DALI
Supply Voltage	9.5-22.5 VDC
Supply Current	9 mA
IEC Overvoltage Category	III

Control

Communication Ports	1 x DALI
Dry Contact Inputs	4

Physical

Dimensions (H x W x D)	18 x 34 x 53 mm (0.71 x 1.34 x 2.09 in)
Flylead Length	165 mm (6.50 in) (with bootlace terminals)
Packed Weight	50 g (0.11 lb)
Construction	ABS enclosure
Communication Ports	2 x flylead
Dry Contact Terminals	5 x flylead

Environment*

Operating Temperature	0° to 40°C ambient (32° to 104°F)
Storage/Transport Temperature	-25° to 70°C ambient (-13° to 158°F)
Relative Humidity	0 to 90% non-condensing
IEC Pollution Degree	II

Compliance

Certification	CE, RCM, UL/cUL, FCC, ICES, UKCA, RoHS
---------------	--

* For indoor installation only



Electrical

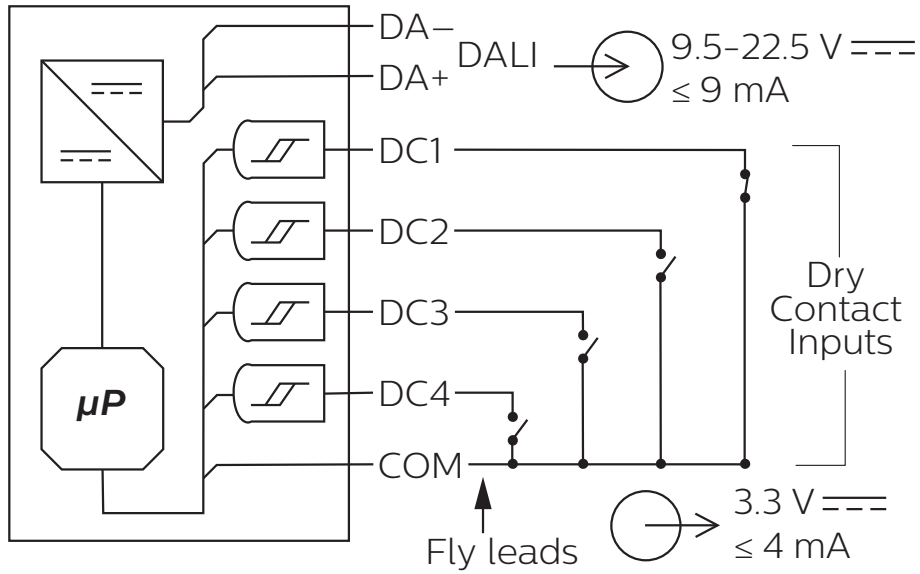

Ordering Code

Product

DPMI940-D

Philips 12NC

913703080609

© 2024 Signify Holding.

All rights reserved. Specifications are subject to change without notice. No representation or warranty as to the accuracy or completeness of the information included herein is given and any liability for any action in reliance thereon is disclaimed. Philips and the Philips Shield Emblem are registered trademarks of Koninklijke Philips N.V. All other trademarks are owned by Signify Holding or their respective owners.



www.dynalite.com

Revision 08 – 2024-01-11