



DDBC516FR

Signal Dimmer Controller

Flexible control of 1-10 V and DALI drivers

The Philips Dynalite DDBC516FR is a five-channel device for controlling DALI drivers. Each control output is selectable to DALI broadcast, DALI addressed, 1-10 V or DSI.

DDBC516FR

Flexible control of 1-10 V and DALI drivers

- **Multiple protocols supported** – Each of the five control outputs supports DALI broadcast (maximum ten DALI loads/channel), DALI addressed (maximum ten DALI loads/channel), 1-10 V (maximum 10 mA sink or source/channel) or DSI (maximum five DSI loads/channel).
- **Built-in energy savings** – Control signals can be programmed to operate in tandem with five internal switched outputs, which will automatically isolate the power circuit when all associated channels are at 0%. This is a useful feature as DALI drivers still draw significant power when lamps are turned off via a DALI command.
- **Integral DALI bus power supply** – Removes the need for an additional external device.
- **Flexible mounting solution** – A DIN-rail mountable device, designed to be installed into the distribution board supplying power to the controlled circuit.
- **Inbuilt diagnostic functionality** – Features lamp and driver failure reporting, driver run time tracking for each driver and the switched output, as well as Device Online/Offline status indication.

Dimensions

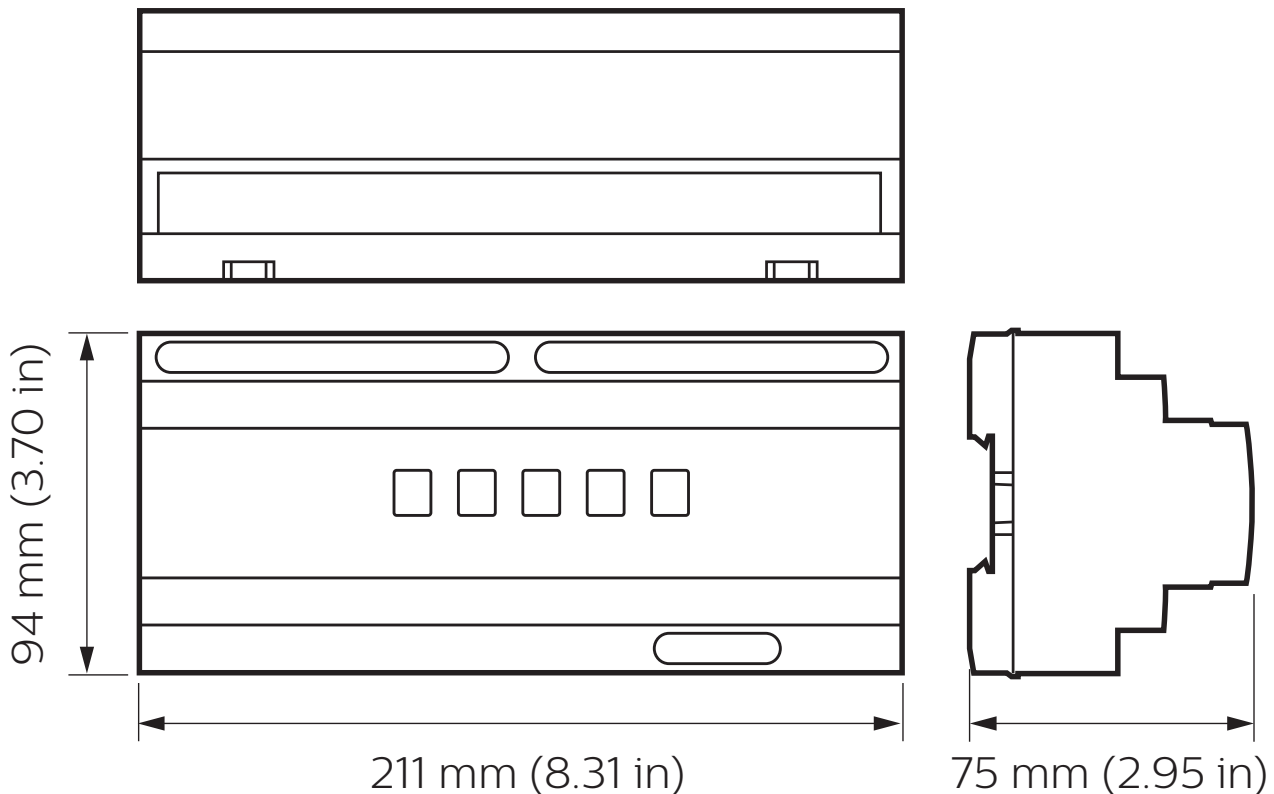

Specifications

Due to continuous improvements and innovations, specifications may change without notice.



DDBC516FR
Signal Dimmer Controller

Electrical

Supply Type	Single-Phase
Supply Voltage	100-240 VAC
Supply Current	0.15 A
DyNet DC Output Voltage	12 VDC
DyNet DC Output Current	120 mA
Switched Outputs	5 x 16 A feed-through
Output Channel Ratings	(See Page 4)
Maximum CH-CH Voltage	300 VAC (UL) 400 VAC (CE)
Maximum CH-XX-CH Voltage*	480 VAC
XX = unpopulated channel (2x terminals) for isolation	
IEC Overvoltage Category	III

Control

Serial Ports	1 x RS-485
Supported Protocols	DyNet
Control Channel Outputs	5 (DALI Broadcast, DALI Addressed, DSI or 1-10 V)
Dry Contact Inputs	1 (AUX)
User Input	1 x service switch 5 x channel override
Indicators	1 x diagnostic LED 5 x channel status LED
Diagnostic Functions**	Lamp failure reporting Driver failure reporting Driver runtime tracking Device online/offline status

* Refer to Installation Instructions for correct terminations for phase separation.

** Philips Dynalite System Manager required for analyzing diagnostic data.
The availability of some diagnostics is dependent on driver type.

Physical

Dimensions (H x W x D)	94 x 211 x 75 mm (3.70 x 8.31 x 2.95 in)
Packed Weight	0.8 kg (1.76 lb)
Construction	Polycarbonate DIN rail enclosure (12 unit)
Serial Ports	2 x RJ12 1 x 6-way pluggable screw terminal
Serial Port Conductor Size	2.5 mm ² (#12 AWG) (max)
Supply Terminals	3 x screw terminal Line, Neutral, Earth
Supply Terminal Conductor Size	5 mm ² (#10 AWG) (max)
Control Terminals	5 x 2-way screw terminal DA-, DA+
Control Terminal Conductor Size	2.5 mm ² (#12 AWG) (max)
Output Terminals	5 x 2-way screw terminal IN, OUT
Output Terminal Conductor Size	5 mm ² (#10 AWG) (max)

Environment***

Operating Temperature	0° to 40°C ambient (32° to 104°F)
Storage/Transport Temperature	-25° to 70°C ambient (-13° to 158°F)
Relative Humidity	0 to 90% non-condensing
IEC Pollution Degree	II

Compliance

Certification	CE, RCM, UL, FCC, ICES, UKCA, RoHS
---------------	------------------------------------

*** For indoor installation only



Electrical

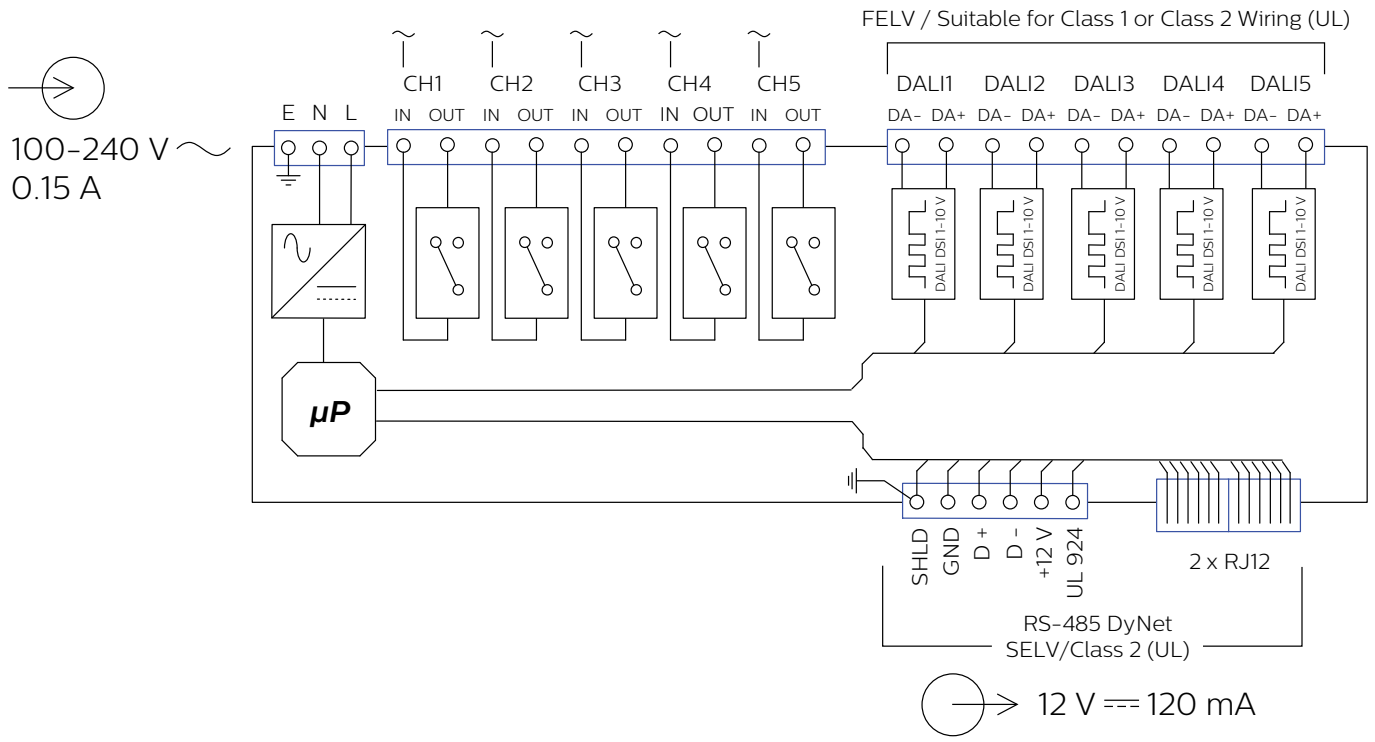

Output Channel Ratings

Load Type	Maximum Rating per Output CH1-CH5
General Use	
Incandescent	16 A, 277 VAC
Standard Driver	
Electronic Driver	
Motor	16 FLA (1 HP), 120 VAC 14.5 FLA (2½ HP), 240 VAC 14.1 FLA (3 HP), 277 VAC
Pilot Duty	6 A, 120 VAC 3 A, 240 VAC 2.6 A, 277 VAC
Inrush Current	500 A
Total Device Load	≤ 80 A

Control Channel Ratings

DALI/DSI	Channel	Device
Guaranteed Current	20 mA	
Maximum Current	250 mA	
Maximum Drivers	10	50
Insulation	Basic	
1-10 V		Channel
Current	sink 10 mA source 10 mA	

Ordering Code

Product

DDBC516FR

Philips 12NC

913703031509

© 2024 Signify Holding.

All rights reserved. Specifications are subject to change without notice. No representation or warranty as to the accuracy or completeness of the information included herein is given and any liability for any action in reliance thereon is disclaimed. Philips and the Philips Shield Emblem are registered trademarks of Koninklijke Philips N.V. All other trademarks are owned by Signify Holding or their respective owners.



www.dynalite.com

Revision 08 – 2024-01-10